

Driver Manual

FS-8700-97 Lutron Machine

APPLICABILITY & EFFECTIVITY

Effective for all systems manufactured after March 2021.



Driver Revision: 1.04
Document Revision: 2.A



fieldserver

MSA Safety
1991 Tarob Court
Milpitas, CA 95035
Website: www.MSAsafety.com

U.S. Support Information:
+1 408 964-4443
+1 800 727-4377
Email: smc-support@msasafety.com

EMEA Support Information:
+31 33 808 0590
Email: smc-support.emea@msasafety.com

Contents

1	Description	4
2	Driver Scope of Supply	4
	2.1 Supplied by MSA Safety.....	4
	2.2 Provided by the Supplier of 3rd Party Equipment	4
	2.2.1 Hardware.....	4
3	Hardware Connections	5
	3.1 Softswitch 128 Wiring	5
	3.1.1 One-Line Diagram	5
	3.1.2 Detailed Diagram	5
	3.2 GRAFIK 7000 Wiring	6
	3.2.1 One-Line Diagram.....	6
	3.2.2 Detailed Diagram	6
4	Data Array Parameters	7
5	Client Side Configuration	8
	5.1 Client Side Connection Parameters	8
	5.2 Client Side Node Descriptors	9
	5.3 Client Side Map Descriptor Parameters	9
	5.3.1 FieldServer Specific Map Descriptor Parameters.....	9
	5.3.2 Driver Related Map Descriptor Parameters	10
	5.3.1 Timing Parameters.....	10
	5.4 Map Descriptor Examples	11
	5.4.1 Binary Output (Zone and Area Machine)	11
	5.4.2 Binary Input (Zone Machine).....	11
	5.4.3 Binary Input (Area Machine)	12
	5.4.4 Analog Output 1 (Area Machine).....	12
	5.4.5 Analog Output 1 (Zone Machine).....	13
	5.4.6 Analog Output 2 (Zone and Area Machine)	14
	5.4.7 Analog Input (Area Machine)	15
	5.4.8 Analog Input (Zone Machine).....	15
	5.4.9 Multistate Output (Zone and Area Machine)	16
	5.4.10 Binary Value (Zone and Area Machine).....	17
	5.4.11 Analog Value (Zone and Area Machine).....	17
6	Useful Features	18
	6.1 Map Descriptor Functions.....	18
	6.2 Lutron Profiles.....	18

1 Description

The Lutron Machine driver allows the FieldServer to transfer data to and from Lutron devices. The FieldServer can emulate either a Server or Client, although the Lutron Machine driver is only available in Client configuration. Server drivers are for FieldServer testing purposes only.

Max Nodes Supported

FieldServer Mode	Nodes	Comments
Client	1	Only one Lutron Machine driver Client node is able to be connected to a Lutron panel.

The Lutron Grafik Machine Zone/Area Machine driver, hereafter simply referred to as the Lutron Machine driver, provides a BACNet/IP interface to a Lutron panel. The driver can be configured to represent zones or areas as used in the Lutron panel. The FieldServer acts as both Client and Server to provide BACnet objects to an external BACnet Client. In Server mode, the FieldServer collects data from the Lutron panel and holds the data ready for reads from an external BACnet Client. In Client mode, the FieldServer executes pre-defined commands on the Lutron panel, for example, running scripts.

2 Driver Scope of Supply

2.1 Supplied by MSA Safety

Part #	Description
FS-8915-10	UTP cable (7 foot) for RS-232 use
FS-8917-03	RJ45 to DB9F connector adapter

2.2 Provided by the Supplier of 3rd Party Equipment

2.2.1 Hardware

Part #	Description
	GRAFIK 7000™
	Softswitch 128®

3 Hardware Connections

The Softswitch 128 and GRAFIK 7000 systems can be integrated using the QuickServer gateway. Wiring is performed as shown below.

3.1 Softswitch 128 Wiring

3.1.1 One-Line Diagram

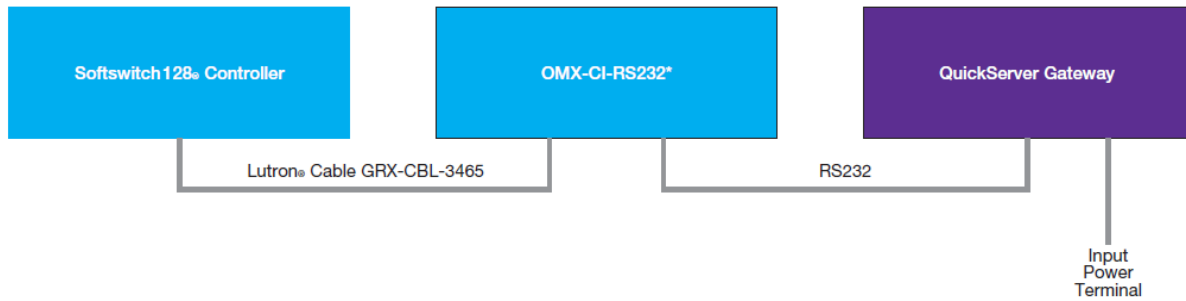

3.1.2 Detailed Diagram

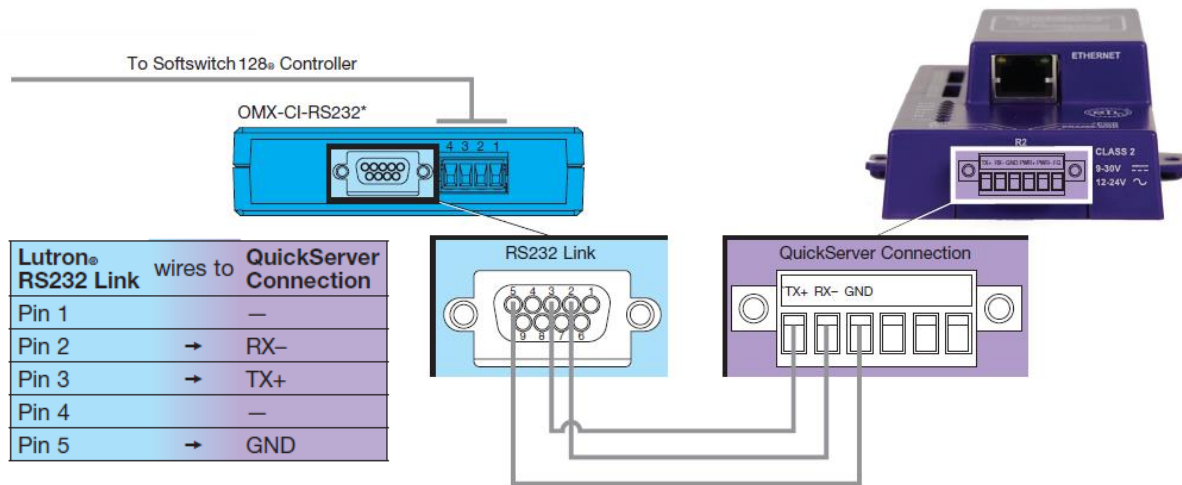

* The OMX-CI-RS232 must be purchased from Lutron to interface between the Softswitch 128® controller and the QuickServer gateway.

NOTE: The QuickServer 2XX0 form factor is also compatible for connection. Connect either the R1 or R2 3-pin port to the same label pins as shown in the diagram above. See [QuickServer 2XX0 Start-Up Guide](#) for more information.

Installing the FieldServer

3.2 GRAFIK 7000 Wiring

3.2.1 One-Line Diagram

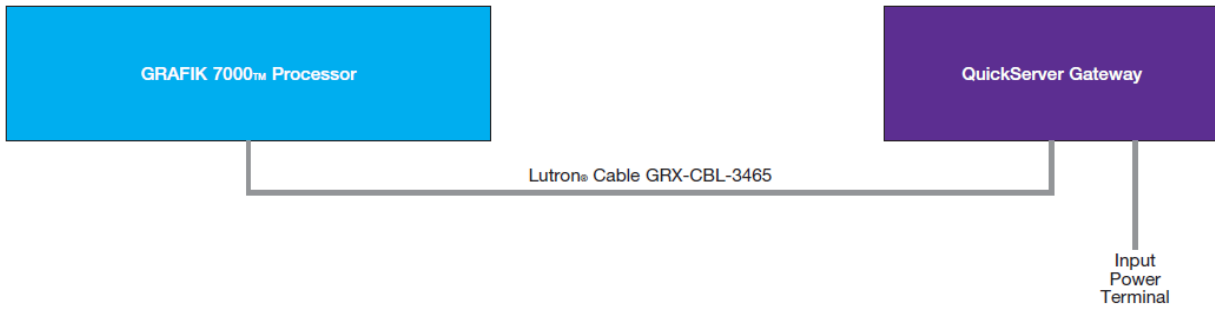

3.2.2 Detailed Diagram

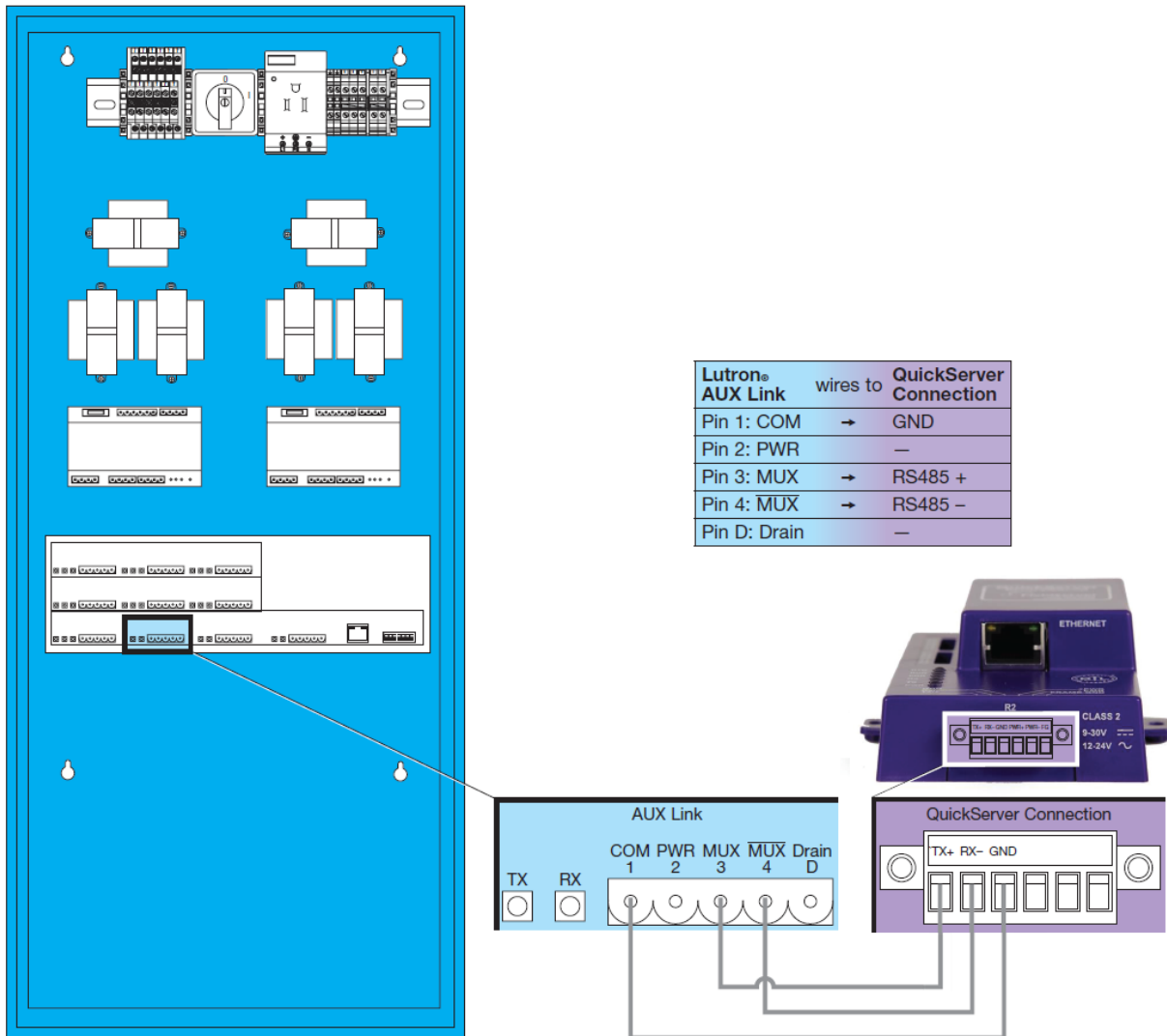

NOTE: The QuickServer 2XX0 form factor is also compatible for connection. Connect either the R1 or R2 3-pin port to the same label pins as shown in the diagram above. See [QuickServer 2XX0 Start-Up Guide](#) for more information.

4 Data Array Parameters

Data Arrays are “protocol neutral” data buffers for storage of data to be passed between protocols. It is necessary to declare the data format of each of the Data Arrays to facilitate correct storage of the relevant data.

Section Title		
Data_Arrays		
Column Title	Function	Legal Values
Data_Array_Name	Provide name for Data Array.	Up to 15 alphanumeric characters
Data_Array_Format	Provide data format. Each Data Array can only take on one format.	Float, Bit, Byte, Uint16, Uint32, Sint16, Sint32
Data_Array_Length	Number of Data Objects. Must be larger than the data storage area required by the Map Descriptors for the data being placed in this array.	1-10000

Example

```
// Data Arrays
Data_Arrays
Data_Array_Name , Data_Array_Format , Data_Array_Length
Binary_Output , Bit , 512
Binary_Input , Bit , 512
Analog_Output , Uint16 , 512
Analog_Input , Uint16 , 512
```

5 Client Side Configuration

For detailed information on FieldServer configuration, refer to the FieldServer Configuration Manual. The information that follows describes how to expand upon the factory defaults provided in the configuration files included with the FieldServer (see “.csv” sample files provided with the FieldServer).

This section documents and describes the parameters necessary for configuring the FieldServer to communicate with a Lutron panel.

The configuration file tells the FieldServer about its interfaces, and the routing of data required. In order to enable the FieldServer for Lutron panel communications the following three actions must be taken. The driver independent FieldServer buffers need to be declared in the “Data Arrays” section. The destination device addresses need to be declared in the “Client Side Nodes” section. And the data required from the server(s) needs to be mapped in the “Client Side Map Descriptors” section. Details on how to perform these steps can be found below.

NOTE: In the tables below, * indicates an optional parameter, with the bold legal value as default.

5.1 Client Side Connection Parameters

Section Title		
Connections		
Column Title	Function	Legal Values
Port	Specify which port the device is connected to the FieldServer.	P1-P2, R1-R2 ¹
Protocol	Specify protocol used.	eLumen, Lutron_Machine
Baud*	Specify baud rate.	9600 (Vendor limitation)
Parity*	Specify parity.	None (Vendor limitation)
Data_Bits*	Specify data bits.	8 (Vendor limitation)
Stop_Bits*	Specify stop bits.	1 (Vendor limitation)
Poll_Delay*	Time between internal polls.	0-32000 seconds, 1 second

Example

```
// Client Side Connections
Connections
Port , Protocol , Baud , Parity , Poll_Delay
P1 , Lutron_Machine , 9600 , None , 0.100s
```

¹ Not all ports shown may be supported by the hardware. Consult the appropriate Instruction manual for details of the hardware.

5.2 Client Side Node Descriptors

Section Title		
Nodes		
Column Title	Function	Legal Values
Node_Name	Provide name for node.	Up to 32 alphanumeric characters
Node_ID	The Lutron processor address. Only decimal values are allowed (for example, 11 hex must be entered as 17).	0-255
Protocol	Specify protocol used.	eLumen, Lutron_Machine
Connection	Specify through which port the device is connected to the FieldServer.	P1-P2, R1-R2 ¹
Node_Type	Specifies the Lutron command and data format.	Hex, Decimal

Example

```
// Client Side Nodes
Nodes
Node_Name , Node_ID , Protocol , Port , Node_Type
LUT_GRF6_0 , 17 , Lutron_Machine , P1 , Hex
```

5.3 Client Side Map Descriptor Parameters

5.3.1 FieldServer Specific Map Descriptor Parameters

Column Title	Function	Legal Values
Map_Descriptor_Name	Name of this Map Descriptor.	Up to 32 alphanumeric characters
Data_Array_Name	Name of Data Array where data is to be stored in the FieldServer.	One of the Data Array names from "Data Array" section above
Data_Array_Offset	Starting location in Data Array.	0 to maximum specified in "Data Array" section above
Function	Function of Client Map Descriptor.	ARCO, AWT, RDBC, Passive Client, ARCS; refer to Section 6.1 for more information

5.3.2 Driver Related Map Descriptor Parameters

Column Title	Function	Legal Values
Node_Name	Name of Node to fetch data from.	One of the node names specified in “Client Node Descriptor” above
Grafik_Command	Specifies the command that will be sent to the Lutron Panel.	Area Machine
		Run_Script_AB, Area_Sts_Offscene, Sel_Scene_In_Area, Run_Script_Multi, Area_Status, Scene_In_Area_Status, Sys_Var_Val_Bin, Sys_Var_Val
		Zone Machine
		Run_Script_Ab, Zone_Intensity, Fade_Zone, Run_Script_Multi, Zone_Intensity, Sys_Var_Val_Bin, Sys_Var_Val
DA_Lut_List	Name of Data Array that contains a list of parameters needed to execute the command.	A Data Array name
DA_Lut_List_Offset	The offset into the DA_Lut_List Data Array from where the list data is to be used.	0 to the maximum offset into the DA_Lut_List Data Array
DA_Lut_Parms	Name of Data Array that contains parameters needed to execute the command.	A Data Array name
DA_Lut_Parms_Offset	The offset into the DA_Lut_Parms Data Array where the driver will retrieve the parameters.	0 to the maximum offset into the DA_Lut_Parms Data Array
Area	GRAFIK system area number.	0 – 511
Sys_var	GRAFIK system variable number.	0 – 65535
Zone	GRAFIK system zone number.	0 – 511
Length	Length of Map Descriptor. The length is an indication of the number of data elements this Map Descriptor is responsible for updating. It is used in the overall points calculation of the FieldServer.	See Section 5.4 for individual lengths per Map Descriptor
Multi_Scripts_Length	The length of the Data Array specified under DA_Lut_List when used with Grafik command: run_script_multi.	1 – 10000

5.3.1 Timing Parameters

Column Title	Function	Legal Values
Scan_Interval*	Rate at which data is polled.	≥0.001s, 1

5.4 Map Descriptor Examples

5.4.1 Binary Output (Zone and Area Machine)

A write to the Binary Output Data Array which is shared by a BACnet/IP Map Descriptor will execute one of two scripts on the Lutron panel. The script numbers corresponding to binary inactive (0) and active (1) are specified in the Data Array specified by DA_Lut_List from offset specified by DA_Lut_List_Offset. Script numbers are in decimal and range from 0 to 65535.

BACnet/IP Map Descriptor

```
// Client Side Map Descriptors
Map_Descriptors
Map_Descriptor_Name , Data_Array_Name , Data_Array_Offset , Function , Node_Name , Data_Type , Object_ID , Length , Relinquish_Default
SMD00_BO , Binary_Output , 0 , Passive , Virtual_BCU_11 , BO , 1 , 512 , 0
```

Lutron Machine Map Descriptor

```
// Client Side Map Descriptors
Map_Descriptors
Map_Descriptor_Name , Data_Array_Name , Data_Array_Offset , Function , Node_Name , Grafik_Command
Run_Script_0 , Binary_Output , 0 , Awt , LUT_GRF6_0 , run_script_AB
```

```
, DA_Lut_List , DA_Lut_List_Offset , Length
, Script_list_BO , 0 , 512
```

The Data Array specified under “DA_Lut_List” must be preloaded with script numbers as shown below:

- ScriptA in even locations, ScriptB in uneven locations, values in Preload_Data_Value.
- ScriptA will be run when writing zero into the Object ID.
- ScriptB will be run when writing non-zero into the object ID.

```
Preloads
Data_Array_Name , Preload_Data_Format , Preload_Data_Value , Location
// Binary Output Object ID 1
Script_list_BO , Uint16 , 1 , 0
Script_list_BO , Uint16 , 2 , 1
// Binary Output Object ID 2
Script_list_BO , Uint16 , 3 , 2
Script_list_BO , Uint16 , 4 , 3
```

5.4.2 Binary Input (Zone Machine)

A read from the Binary Input Data Array which is shared by a BACnet/IP Map Descriptor will return the relay state for the given zone. The Lutron Machine Map Descriptor regularly polls the Lutron panel to retrieve the value of zone intensity. The value of each BACnet object presenting Binary Output is inactive if the intensity is zero and active if the intensity is non-zero. Zone numbers range from 0 to 511.

BACnet/IP Map Descriptor

```
// Client Side Map Descriptors
Map_Descriptors
Map_Descriptor_Name , Data_Array_Name , Data_Array_Offset , Function , Node_Name , Data_Type , Object_ID , Length , Relinquish_Default
SMD00_BI , Binary_Input , 0 , Passive , Virtual_BCU_11 , BI , 1 , 512 , 0
```

Lutron Machine Map Descriptor

```
// Client Side Map Descriptors
Map_Descriptors
Map_Descriptor_Name , Data_Array_Name , Data_Array_Offset , Function , Node_Name , Grafik_Command , Zone , Length
Zone_int_0 , Binary_Input , 0 , Arco , LUT_GRF6_0 , Zone_Intensity , 0 , 512
```

5.4.3 Binary Input (Area Machine)

A read from the Binary Input Data Array which is shared by a BACnet/IP Map Descriptor will return the scene-on state for the given area. The Lutron Machine Map Descriptor regularly polls the Lutron Panel to retrieve the scene-on state for the given area. The value returned by the BACnet object is inactive (0) if the off scene is selected and active (1) if any other scene is selected. The off scene numbers range from 0 to 65535 and are preloaded in the Data Array specified under “DA_Lut_List”.

BACnet/IP Map Descriptor

```
// Client Side Map Descriptors

Map_Descriptors
Map_Descriptor_Name , Data_Array_Name , Data_Array_Offset , Function , Node_Name , Data_Type , Object_ID , Length , Relinquish_Default
SMD00_BI , Binary_Input , 0 , Passive , Virtual_BCU_11 , BI , 1 , 512 , 0
```

Lutron Machine Map Descriptor

```
// Client Side Map Descriptors

Map_Descriptors
Map_Descriptor_Name , Data_Array_Name , Data_Array_Offset , Function , Node_Name , Grafik_Command
Area_sts_0 , Binary_Input , 0 , Arco , LUT_GRF6_0 , Area_Sts_Offscene

, Area , DA_Lut_List , DA_Lut_List_Offset , Length
0 , Off_Scene , 0 , 512
```

```
Preloads
Data_Array_Name , Preload_Data_Format , Preload_Data_Value , Location

// Binary Input Object ID 1
off_scene , Uint16 , 0 , 0

// Binary Input Object ID 2
off_scene , Uint16 , 1 , 1
```

Insert the off-scene number into the Preload_Data_Value field.

5.4.4 Analog Output 1 (Area Machine)

A write to the Analog Output Data Array which is shared by a BACnet/IP Map Descriptor will command an area to a preset scene on the Lutron Panel. Scenes range from 0 to 65535 and area numbers range from 0 to 511.

BACnet/IP Map Descriptor

```
// Client Side Map Descriptors

Map_Descriptors
Map_Descriptor_Name , Data_Array_Name , Data_Array_Offset , Function , Node_Name , Data_Type , Object_ID , Length , Relinquish_Default
SMD000_AO , Analog_Output , 0 , Passive , Virtual_BCU_11 , AO , 1 , 512 , 0
```

Lutron Machine Map Descriptor

```
// Client Side Map Descriptors

Map_Descriptors
Map_Descriptor_Name , Data_Array_Name , Data_Array_Offset , Function , Node_Name , Grafik_Command , Area , Length
Sel_scene_0 , Analog_Output , 0 , Awt , LUT_GRF6_0 , Sel_Scene_In_Area , 0 , 512
```

The area field must be used to indicate the start area number that will be associated with the first element of the Data Array specified under Data_Array_Name. Area numbers increase with the Length field in association with increasing offset into the Data Array.

5.4.5 Analog Output 1 (Zone Machine)

A write to the Analog Output Data Array which is shared by a BACnet/IP Map Descriptor will command a zone on the Lutron panel to the written intensity. Intensities are written as a percentage value (0 to 100%).

BACnet/IP Map Descriptor

```
// Client Side Map Descriptors
Map_Descriptors
Map_Descriptor_Name , Data_Array_Name , Data_Array_Offset , Function , Node_Name , Data_Type , Object_ID , Length , Relinquish_Default
SMD000_AO , Analog_Output , 0 , Passive , Virtual_BCU_11 , AO , 1 , 512 , 0
```

Lutron Machine Map Descriptor

```
// Client Side Map Descriptors
Map_Descriptors
Map_Descriptor_Name , Data_Array_Name , Data_Array_Offset , Function , Node_Name , Grafik_Command
Fade_to_Ivl_0 , Analog_Output , 0 , Awt , LUT_GRF6_0 , Fade_Zone

, Zone , DA_Lut_Parms , DA_Lut_Parms_Offset , Length
, 0 , Zone_Pars_AO1 , 0 , 512
```

The zone field must be used to indicate the start zone number that will be associated with the first element of the Data Array specified under Data_Array_Name. Zone numbers increase with the Length field in association with increasing offset into the Data Array.

Fade and Delay times per zone must be preloaded into the Data Array specified under “DA_Lut_Parms”.

Analog Output1 Settings Setup:

- All values are in decimal (0 - 65535).
- Fade time in even locations, Delay time in uneven locations.
- Fill in time values under Preload_Data_Value.

```
Preloads
Data_Array_Name , Preload_Data_Format , Preload_Data_Value , Location
// Analog Output1 Object ID 1
Zone_pars_AO1 , Uint16 , 0 , 0
Zone_pars_AO1 , Uint16 , 1 , 1
// Analog Output1 Object ID 2
Zone_pars_AO1 , Uint16 , 2 , 2
Zone_pars_AO1 , Uint16 , 3 , 3
```

5.4.6 Analog Output 2 (Zone and Area Machine)

A write to the Analog Output Data Array, which is shared by a BACnet/IP Map Descriptor, will execute one of multiple scripts on the Lutron panel. The value written into the Analog Output Data Array is used as an offset into the Data Array defined under “DA_Lut_List” to retrieve a script number. Script numbers range from 0 to 65535.

BACnet/IP Map Descriptor

```
// Client Side Map Descriptors

Map_Descriptors
Map_Descriptor_Name , Data_Array_Name , Data_Array_Offset , Function , Node_Name , Data_Type , Object_ID , Length , Relinquish_Default
SMD512_AO , Analog_Output , 512 , Passive , Virtual_BCU_11 , AO , 513 , 512 , 0
```

Lutron Machine Map Descriptor

```
// Client Side Map Descriptors

Map_Descriptors
Map_Descriptor_Name , Data_Array_Name , Data_Array_Offset , Function , Node_Name , Grafik_Command
Run_script_512 , Analog_Output , 512 , Awt , LUT_GRF6_0 , Run_Script_Multi

, DA_Lut_List , DA_Lut_List_Offset , Length , Multi_Scripts_Length
, Scr_Lst_AO2_512 , 0 , 1 , 10
```

The Multi_Scripts_Length field is used to indicate the maximum size of the Data Array specified under Data_Array_Name. One Map Descriptor per object must be defined with a Multi_Scripts_Length value of 1 or greater.

The script numbers need to be preloaded into the Data Arrays defined under “DA_Lut_List”.

Analog Output2 Settings Setup:

- All values are in decimal (0 - 65535).
- Specify up to 10 scripts for each Object ID by editing Preload_Data_Value.

```
Preloads
Data_Array_Name , Preload_Data_Format , Preload_Data_Value , Location

// Analog Output2 Object ID 513
Scr_Lst_AO2_512 , Uint16 , 100 , 0
Scr_Lst_AO2_512 , Uint16 , 200 , 1
Scr_Lst_AO2_512 , Uint16 , 300 , 2
Scr_Lst_AO2_512 , Uint16 , 400 , 3
Scr_Lst_AO2_512 , Uint16 , 500 , 4
Scr_Lst_AO2_512 , Uint16 , 600 , 5
Scr_Lst_AO2_512 , Uint16 , 700 , 6
Scr_Lst_AO2_512 , Uint16 , 800 , 7
Scr_Lst_AO2_512 , Uint16 , 900 , 8
Scr_Lst_AO2_512 , Uint16 , 65000 , 9

// Analog Output2 Object ID 514
Scr_Lst_AO2_513 , Uint16 , 101 , 0
Scr_Lst_AO2_513 , Uint16 , 201 , 1
Scr_Lst_AO2_513 , Uint16 , 301 , 2
Scr_Lst_AO2_513 , Uint16 , 401 , 3
Scr_Lst_AO2_513 , Uint16 , 501 , 4
Scr_Lst_AO2_513 , Uint16 , 601 , 5
Scr_Lst_AO2_513 , Uint16 , 701 , 6
Scr_Lst_AO2_513 , Uint16 , 801 , 7
Scr_Lst_AO2_513 , Uint16 , 901 , 8
Scr_Lst_AO2_513 , Uint16 , 65001 , 9
```

5.4.7 Analog Input (Area Machine)

A read from the Analog Input Data Array which is shared by a BACnet/IP Map Descriptor will return the last scene selected in a given area on the Lutron Panel. The Lutron Machine Map Descriptor regularly polls the Lutron Panel to retrieve the scene numbers.

BACnet/IP Map Descriptor

```
// Client Side Map Descriptors

Map_Descriptors
Map_Descriptors_Name , Data_Array_Name , Data_Array_Offset , Function , Node_Name , Data_Type , Object_ID , Length
SMD00_AI , Analog_Input , 0 , Server , Virtual_BCU_11 , AI , 1 , 1

, Relinquish_Default , Data_Array_Low_Scale , Data_Array_High_Scale , Node_Low_Scale , Node_High_Scale
, 0 , 0 , 100 , 0 , 100
```

The last scene value may be scaled.

Analog Input Settings Setup:

- All values are in decimal (0 - 65535).
- Insert a first available scene number under the Data_Array_High_Scale field for each Object ID or use the scale fields as desired to scale scene numbers.
- Object IDs are contiguous.

Lutron Machine Map Descriptor

```
// Client Side Map Descriptors

Map_Descriptors
Map_Descriptor_Name , Data_Array_Name , Data_Array_Offset , Function , Node_Name , Grafik_Command , Area , Length
Last_scene_0 , Analog_Input , 0 , Arco , LUT_GRF6_0 , Area_Status , 0 , 512
```

5.4.8 Analog Input (Zone Machine)

A read from the Analog Input Data Array which is shared by a BACnet/IP Map Descriptor will return the intensity to which a given zone is set on the Lutron Panel. The Lutron Machine Map Descriptor regularly polls the Lutron Panel to retrieve the zone intensities. The intensity value returned is scaled to a percentage value (0 to 100%). Zone numbers range from 0 to 511.

BACnet/IP Map Descriptor

```
// Client Side Map Descriptors

Map_Descriptors
Map_Descriptor_Name , Data_Array_Name , Data_Array_Offset , Function , Node_Name , Data_Type , Object_ID , Length , Relinquish_Default
SMD00_AI , Analog_Input , 0 , Passive , Virtual_BCU_11 , AI , 1 , 512 , 0
```

Lutron Machine Map Descriptor

```
// Client Side Map Descriptors

Map_Descriptors
Map_Descriptor_Name , Data_Array_Name , Data_Array_Offset , Function , Node_Name , Grafik_Command , Zone , Length
Zone_inta_0 , Analog_Input , 0 , Arco , LUT_GRF6_0 , Zone_Intensity , 0 , 512
```

5.4.9 Multistate Output (Zone and Area Machine)

A write to the Multistate Output Data Array which is shared by a BACnet/IP Map Descriptor will execute one of multiple scripts. The multiple scripts are specified in the Data Array defined under "DA_Lut_List". The value written into the Multistate Output Data Array is used as the offset into the Data Array defined under "DA_Lut_List" to retrieve a script number from the Data Array. Script numbers range from 0 to 65535.

BACnet/IP Map Descriptor

```
// Client Side Map Descriptors

Map_Descriptors
Map_Descriptor_Name , Data_Array_Name , Data_Array_Offset , Function , Node_Name , Data_Type , Object_ID , Length , Relinquish_Default
SMD00_MO , MultiSt_Output , 0 , Passive , Virtual_BCU_11 , MO , 1 , 512 , 0
```

Lutron Machine Map Descriptor

```
// Client Side Map Descriptors

Map_Descriptors
Map_Descriptor_Name , Data_Array_Name , Data_Array_Offset , Function , Node_Name , Grafik_Command
Run_scripts_0 , MultiSt_Output , 0 , Awt , LUT_GRF6_0 , Run_Script_Multi

, DA_Lut_List , DA_Lut_List_Offset , Length , Multi_Scripts_Length
, Scr_Lst_MSO_0 , 0 , 1 , 10
```

The Multi_Scripts_Length field is used to indicate the maximum size of the Data Array specified under Data_Array_Name. One Map Descriptor per object must be defined with a Multi_Scripts_Length value of one or greater.

The scripts per object element must be preloaded into the Data Array defined under "DA_Lut_List".

Multistate Output Scripts Setup:

- All values are in decimal (0 - 65535).
- Specify up to 10 scripts for each Object ID by editing Preload_Data_Value.

Preloads	Data_Array_Name	Preload_Data_Format	Preload_Data_Value	Location
// Multistate Output Object ID 1				
Scr_Lst_MSO_0		Uint16	, 110	, 0
Scr_Lst_MSO_0		Uint16	, 210	, 1
Scr_Lst_MSO_0		Uint16	, 310	, 2
Scr_Lst_MSO_0		Uint16	, 410	, 3
Scr_Lst_MSO_0		Uint16	, 510	, 4
Scr_Lst_MSO_0		Uint16	, 610	, 5
Scr_Lst_MSO_0		Uint16	, 710	, 6
Scr_Lst_MSO_0		Uint16	, 810	, 7
Scr_Lst_MSO_0		Uint16	, 910	, 8
Scr_Lst_MSO_0		Uint16	, 65010	, 9
// Multistate Output Object ID 2				
Scr_Lst_MSO_1		Uint16	, 120	, 0
Scr_Lst_MSO_1		Uint16	, 220	, 1
Scr_Lst_MSO_1		Uint16	, 320	, 2
Scr_Lst_MSO_1		Uint16	, 420	, 3
Scr_Lst_MSO_1		Uint16	, 520	, 4
Scr_Lst_MSO_1		Uint16	, 620	, 5
Scr_Lst_MSO_1		Uint16	, 720	, 6
Scr_Lst_MSO_1		Uint16	, 820	, 7
Scr_Lst_MSO_1		Uint16	, 920	, 8
Scr_Lst_MSO_1		Uint16	, 65020	, 9

5.4.10 Binary Value (Zone and Area Machine)

A read from the Binary Value Data Array which is shared by a BACnet/IP Map Descriptor will return the current value of a system variable in the Lutron Panel. The value returned is inactive (0) if the system variable is zero and active (1) if non-zero. The Lutron Machine Map Descriptor regularly polls the Lutron panel to retrieve the system variable values. A write to the Binary Value Data Array will set the system variable to 255 on active (1) write or to zero on inactive (0) write.

BACnet/IP Map Descriptor

```
// Client Side Map Descriptors

Map_Descriptors
Map_Descriptor_Name , Data_Array_Name , Data_Array_Offset , Function , Node_Name , Data_Type , Object_ID , Length , Relinquish_Default
SMD00_BV , Binary_Value , 0 , Passive , Virtual_BCU_11 , BV , 1 , 512 , 0
```

Lutron Machine Map Descriptor

```
// Client Side Map Descriptors

Map_Descriptors
Map_Descriptor_Name , Data_Array_Name , Data_Array_Offset , Function , Node_Name , Grafik_Command , Sys_Var , Length
Zone_var_0 , Binary_Value , 0 , Arco , LUT_GRF6_0 , Sys_Var_Val_Bin , 0 , 512
```

5.4.11 Analog Value (Zone and Area Machine)

A read from the Analog Value Data Array which is shared by a BACnet/IP Map Descriptor will return the current value of a system variable in the Lutron Panel. The variable values range from 0 to 255. The Lutron Machine Map Descriptors are regularly updated with system variable values from the active Binary Value Map Descriptors. A write to the Analog Value Data Array will set the system variable to the written value.

BACnet/IP Map Descriptor

```
// Client Side Map Descriptors

Map_Descriptors
Map_Descriptor_Name , Data_Array_Name , Data_Array_Offset , Function , Node_Name , Data_Type , Object_ID , Length , Relinquish_Default
SMD00_AV , Analog_Value , 0 , Passive , Virtual_BCU_11 , AV , 1 , 512 , 0
```

Lutron Machine Map Descriptor

```
// Client Side Map Descriptors

Map_Descriptors
Map_Descriptor_Name , Data_Array_Name , Data_Array_Offset , Function , Node_Name , Grafik_Command , Sys_Var , Length
Zone_Vara_0 , Analog_Value , 0 , Passive_Client , LUT_GRF6_0 , Sys_Var_Val , 0 , 512
```

The Passive_Client function is used to prevent double-polling the Lutron Panel for system variables. The Analog Value Map Descriptors should be set up identical to the Binary Value Map Descriptors in terms of the Sys_Var and Length fields to ensure system variable values will be stored correctly.

6 Useful Features

6.1 Map Descriptor Functions

Function	Description
RDBC	The RDBC function will read a block of data of length specified by the “length” parameter and transfer that data to the Data Array specified. Reads are performed continuously at an interval specified by the “Scan_Interval” parameter. The RDBC function also has the ability to perform what is known as “write throughs”. If the driver allows writing to the point related to the Map Descriptor where RDBC is specified, then the RDBC function will write the data in the Data Array back to the point when an update in the associated Data Array is detected. This makes RDBC the ideal function for read/write points.
ARCO	The Arco function is the same as RDBC except that the length of the Map Descriptor is taken as the number of zones to poll. The start zone number is specified under the Zone Map Descriptor field. More than one ARCO Map Descriptor may be used to poll two series of zone numbers (for example: from 5-10 and from 300-340). ARCO Map Descriptors with Length 1 perform the same function as RDBC Map Descriptors with the same length.
AWT	This function is used to affect a single data write per trigger. The write only occurs when the Data Array is updated.
Passive_Client	The Server device writes to the FieldServer’s Data Arrays, and the Client device reads the data from the same Data Arrays.
ARCS	This function will perform the same operation as an RDBC (ARC) function but will sequence through the range of addresses starting at "Address" and wrapping at "Address + Length". A length of 1 will be used for every one of the Addresses that gets polled.

6.2 Lutron Profiles

MSA Safety carries pre-made profiles if needed:

- Lutron Grafik 7000 to BACnet/IP (P/N FS-QS-1210-0718) with PG16000008
- Lutron Softswitch 128 to BACnet/IP (P/N FS-QS-1220-0718) with PG16000008
- Lutron Grafik 7000 to BACnet MS/TP (P/N FS-QS-1210-1241) with PG16000007
- Lutron Softswitch 128 to BACnet MS/TP (P/N FS-QS-1220-1241) with PG16000007

For additional details, find the “Lutron to FieldServer Integration Details” ENOTE document on the MSA Safety Website.

Contact FieldServer support for a [quote](#).